



LSBU50DZ

Wine Cellar service

Built-under counter



GENERAL INFORMATION

Capacity : 46

Number of zones : 2

Operating temperature range : 5-20°C

Noise level : 39dB

Energy efficiency class : F

Climate class : SN/ST (10-38)

EPREL code : 2564283

Vinotag compatible : Yes

Product description

The wine cooler designed for your tasting moments

This built-in under-counter wine cooler appeals to wine lovers looking for style and functionality in a compact format. Thanks to its dual temperature zones, each bottle is stored under ideal conditions to preserve and fully express its aromas.

Featuring a **plinth recess**, it integrates discreetly beneath the worktop and fits naturally into your interior. Its reversible door with **integrated handle** makes it easy to adapt to your layout, while compatibility with the Vinotag app gives you precise and intuitive control over your wine collection. A successful blend of innovation, design, and oenological excellence.



INTEGRATED HANDLE

For a discreet and seamless design

Recess plinth

Front ventilated with mounted ventilation base for installation in niches.

WOODEN SHELF

Traditional and aesthetic they absorb vibrations

VINOTAG COMPATIBLE

Free wine cellar management application. Access a virtual representation of your cellar and a detailed inventory

LSBU50DZ

EAN-13 - 3541362506252

Capacity and Temperature

- **Number of bottles: 46**
 - Upper zone : 16
 - Lower zone : 30
- **Adjustable temperature: 5-20°C**
 - Upper zone : 5-20°C
 - Lower zone : 5-20°C

Door

Door color : Black
Door glass color : Grey
Number of glass layers : 3
Anti-UV : Yes
Low-e glass : Yes
Tempered glass : Yes
Reversible door : Yes
Handle type : Integrated
Door dimensions (WxDxH) : 58.9x5x71.4

Security

Alarm : Temperature
Child lock : Yes
Temperature memory : Yes

Logistic

Net dimensions (WxDxH): 59.5 x 57.0 x 82.0
Gross dimensions (WxDxH): 66.0 x 62.5 x 88.0
Net weight (kg) : 47.0
Gross weight (kg) : 51.0

Technical Data

Energy class : F
Annual energy (KWh/a) : 105
Climate class : SN/ST (10-38)
Noise level : 39dB / C
Energy Efficiency Index : 122 %
Power input : 200.00 W
Voltage : 220-240 V
Length of power cable : 150 cm
Type of gas : R600a
Gas charge : 35 g
Mainly recyclable product : Yes
Type of compressor : Inverter
Main cooling system : Air moving system
Charcoal filter : 1
Anti-vibration system : Yes
Adjustable feet : 4 / 1.5 cm

Light

Light source : LED
Light color(s) : White
Dimmable light : no
Light switch : yes
Permanent light option : Yes

Qty per 20' : 54
Qty per 40' : 114
Qty per 40 HC : 170
Customs code :

LSBU50DZ

EAN-13 - 3541362506252

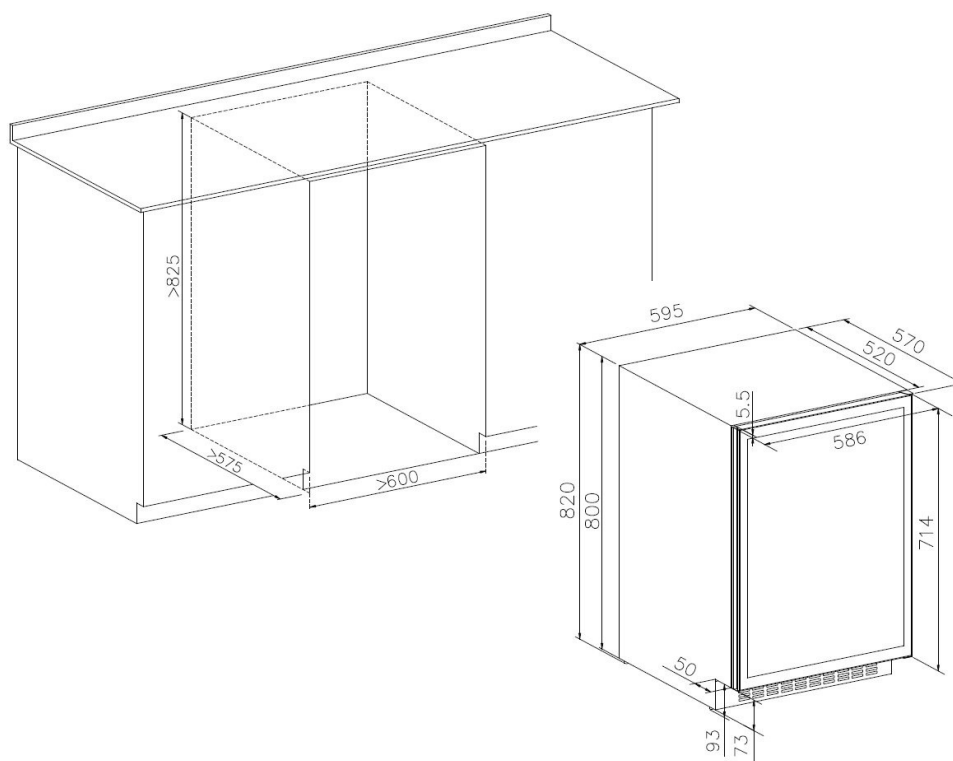

Accessories

- 5 shelves, wooden, sliding
- 1 charcoal filter, (FILTRE5)

Compatible accessories references : FILTRE9

Built-in information

Built-in dimensions (WxDxH) : 60.00 x 57.50 x 82.50

Plumbing passage : No

Recessed plinth : Yes / 5.00

Plinth height : 7.60

Installation warning : This product is equipped with a front ventilation system. Follow the installation instructions to ensure proper operation of the unit.